



**MANUAL DE MONTAGEM  
ASSEMBLY INSTRUCTIONS  
INSTRUCCIONES DE MONTAJE**

**COD BR: BC 84**



# Sumário Summary Resumen

Introdução Introduction Introducción	.....	3
Antes de começar Before starting Antes de comenzar	.....	4
Evite acidentes Avoid accidents Evitar accidentes	.....	4
Dimensões e ferramentas Dimensions and tools Dimensiones y herramientas	.....	5
Identificação das peças Identifying parts Identificación de las piezas	.....	6
Acessórios incluídos na caixa Hardware included in box Accesorios incluidos en la caja	.....	7
Montagem do móvel Furniture assembly Montaje del mueble	.....	8

## Introdução Introduction Introducción

Leia atentamente este manual e siga os passos indicados para que o produto não perca a garantia e também para uma perfeita montagem.

Read this manual and follow the steps in order to keep the guarantee and also for the perfect fit.

Lea este manual y siga los pasos para que el producto no pierda la garantía y también para el ajuste perfecto.

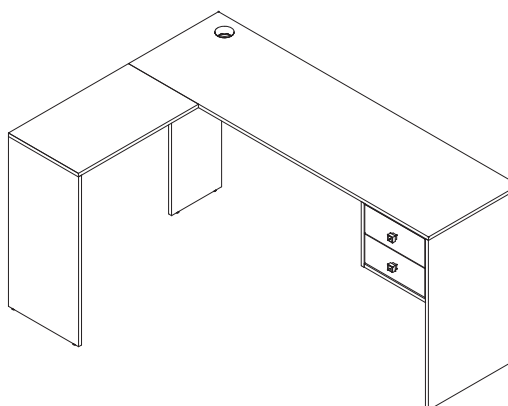

## Antes de começar Before starting Antes de comenzar

Antes de começar a montagem prepare o ambiente, deixando-o completamente limpo e com bom espaço para iniciar o trabalho.

Prepare the room before starting the assembly, leaving it completely clean and the area in good condition to start the work.

Antes de comenzar el montaje preparar el ambiente, dejándolo completamente limpio y con bueno espacio para comenzar el trabajo.

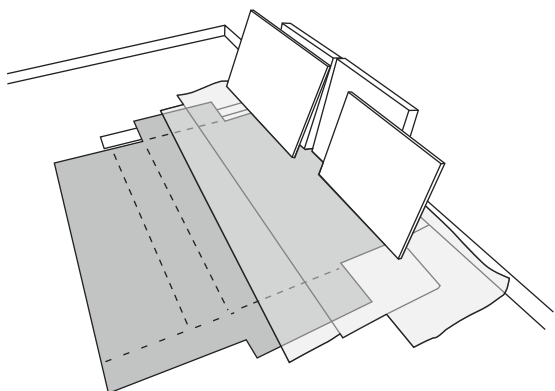

Utilize o papelão da própria embalagem para separar e apoiar as peças retiradas das caixas.

Use the cardboard of the packaging to separate and support the parts removed from the boxes.

Utilice el cartón de la embalaje para separar y apoyar las piezas desmontadas de las cajas.



Forre a área de montagem com um cobertor ou tapete. Assim, você evita avarias nas peças durante o processo de montagem.

Cover the assembly area with a blanket or carpet to avoid damaging the parts during the assembly process.

Cubrir la zona de ensamble con una manta o alfombra. De este modo, se evitan daños en las piezas durante el proceso de montaje.



---

## Evite acidentes Avoid accidents Prevenir accidentes

Solicitamos observar atentamente as orientações de montagem como: fixação do produto na parede, colocação de cola em locais específicos necessários, o peso suportado pelo produto, etc...

We request you to carefully observe the assembly instructions as: fixing the product on the wall, adding glue in needed and specific places, product weight limit, etc.

Pedimos que lea atentamente las instrucciones, principalmente las informaciones de fijación del producto en la pared, colocación de pegamento en local específico y necesario, el peso soportado por el producto etc...

Não escale ou se apoie no móvel.

Do not climb or lean on the furniture.

No se suba ni se apoye en el mueble.

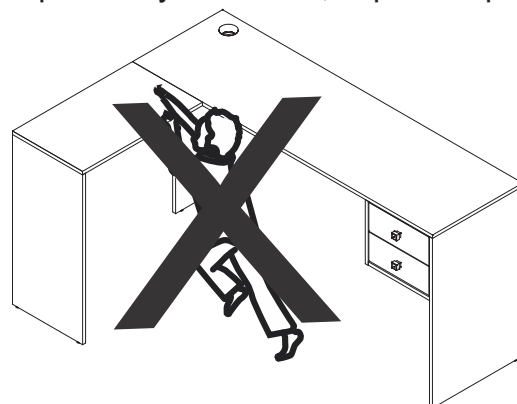

Dimensões e ferramentas  
 Dimensions and tools  
 Dimensiones y herramientas

Dimensões:  
 L: 1500 A: 755 P: 1050 mm  
 Dimensions:  
 W: 59.05 H: 29.72 D: 41.33 inches  
 Dimensiones:  
 L: 1500 A: 755 P: 1050 mm

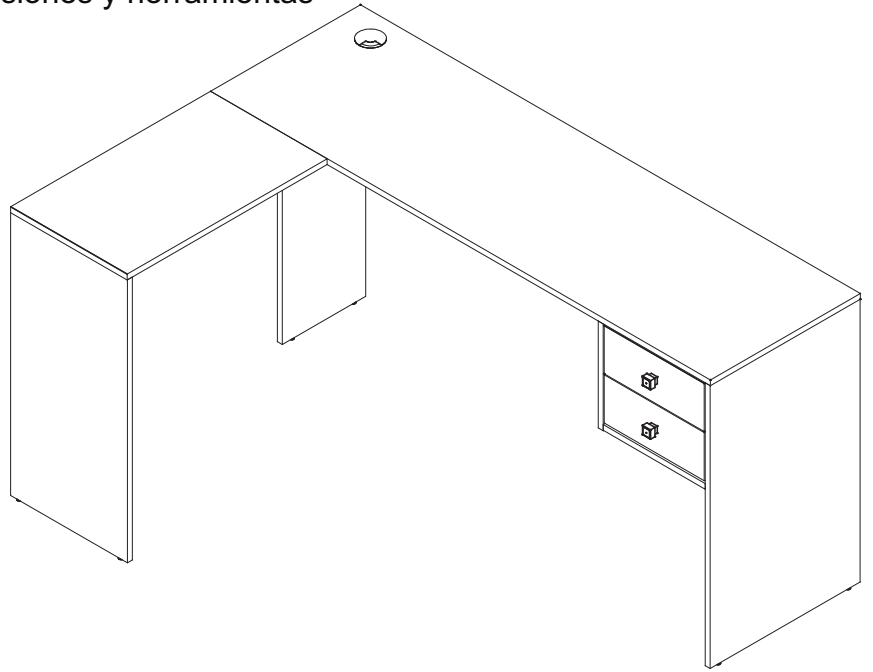

Limpeza  
 Cleaning  
 Limpieza

Pano levemente umedecido com água, seguido de pano seco, não utilizar produtos químico ou abrasivos.  
 You can clean the product with slightly dampened cloth followed by a dry cloth. Do not use chemicals or abrasives.  
 Solamente utilizar un paño húmedo y después un paño seco, no utilice productos químicos o abrasivos.

Todas as peças do móvel foram marcadas com um número. Antes de começar a montagem, identifique as peças numeradas em relação às instruções de montagem. Uma vez concluída a montagem, os números podem ser facilmente removidos com um pano ligeiramente embebido em álcool. Use álcool apenas para remover números das peças.

All the furniture parts have been marked with a number. Before you start assembling, please identify the numbered parts in relation to the assembly instructions. Once assembly is completed, the numbers can be easily removed with a cloth slightly damped in alcohol. Use alcohol only to remove part numbers.

Todos las piezas del mueble fueron marcadas con un número. Antes de empezar el montaje, identifique las piezas numeradas en relación con las instrucciones de montaje. Una vez que se completa el armado, los números se pueden quitar fácilmente con un paño ligeramente empapado en alcohol. Use alcohol solo para eliminar números de las piezas.

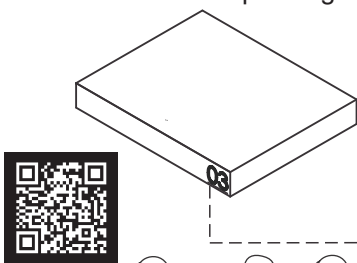

**UTILIZE ALCOOL APENAS PARA REMOVER O NUMERO DAS PEÇAS**  
**USE ALCOHOL ONLY TO REMOVE PART NUMBERS**  
**UTILICE ALCOHOL SOLAMENTE PARA ELIMINAR EL NUMERO DE LAS PIEZAS**

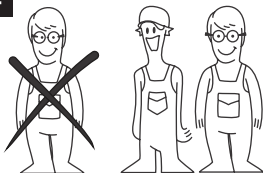

Para facilitar a montagem, utilize uma parafusadeira elétrica.  
 To speed assembly, use an electronic screwdriver.  
 Para facilitar el armado, utilice un destornillador eléctrico.

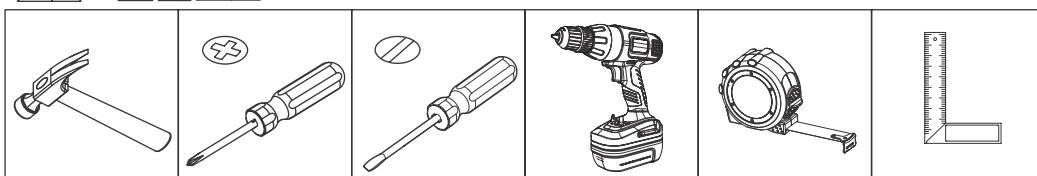

# COD BR: BC 84

PEÇA	DESCRIÇÃO	QUANT.
001	TAMPO MAIOR	1
002	TAMPO MENOR	1
003	LATERAL ESQUERDA	1
004	LATERAL DIREITA	1
005	DIVISÓRIA	1
006	LATERAL ESQUERDA MENOR	1
007	TRAVESSA MENOR	1
008	TRAVESSA MAIOR	1
009	BASE	1
010	FRENTE DE GAVETA	2
011	FUNDO DE GAVETA	2
012	COSTA	1
020	LATERAL DIREITA GAVETA	2
021	COSTA GAVETA	2
022	LATERAL ESQUERDA GAVETA	2

PART	DESCRIPTION	QTY
001	LONGER TOP	1
002	LOWER TOP	1
003	LEFT SIDE	1
004	RIGHT SIDE	1
005	PARTITION	1
006	LOWER LEFT SIDE	1
007	LOWER TRAVERSE	1
008	LONGER TRAVERSE	1
009	BASE	1
010	DRAWER'S FRONT	2
011	DRAWER'S BOTTOM	2
012	BACK	1
020	DRAWER'S RIGHT SIDE	2
021	DRAWER'S BACK	2
022	DRAWER'S LEFT SIDE	2

PIEZA	DESCRIPCIÓN	CANTIDAD
001	TAPA MAYOR	1
002	TAPA MENOR	1
003	LATERAL IZQUIERDA	1
004	LATERAL DERECHA	1
005	PARTICIÓN	1
006	LATERAL IZQUIERDA MENOR	1
007	TRAVESAÑO MENOR	1
008	TRAVESAÑO MAYOR	1
009	BASE	1
010	FRENTE DEL CAJÓN	2
011	FONDO DEL CAJÓN	2
012	REVÉS	1
020	LATERAL DERECHA DEL CAJÓN	2
021	REVÉS CAJÓN	2
022	LATERAL IZQUIERDA DEL CAJÓN	2

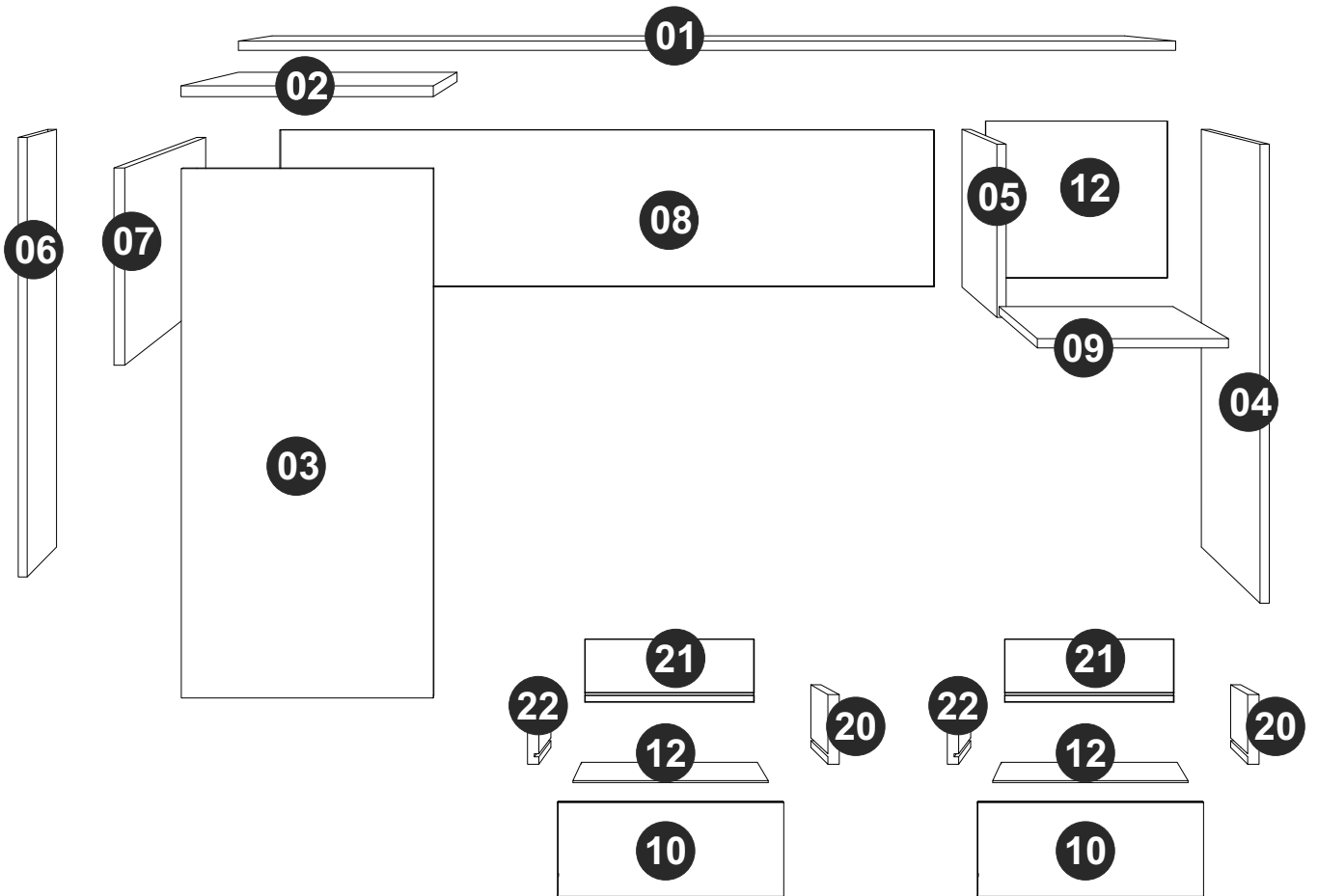



EF 000033 x 26  
8x30



EF 000094 X 25



EF 000724 x 2  
8x40



EF 000168 X 22  
10x10 C/C



EF 000216 X 29

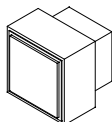

PUXADOR x 2  
HANDLE x 2  
MANIJA x 2



GIZ x 01  
CHALK x 01  
TIZA x 01

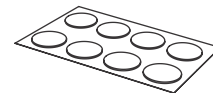

TAPA FUROS x 29  
STICKER x 29  
TAPAS PLÁSTICAS x 29



EF 000112 X 2  
3,5X25 CF

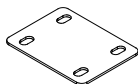

EF 000069 X 2



EF 000750 X 2



EF 000106 x 24  
3,5X14 CC



PÉS REDONDOS x 6  
ROUND FEET x 6  
PIES REDONDOS x 6



PASSA - FIO X 1  
PASS - WIRE x 1  
PASA - CABLE x 1



CORREDIÇAS x 4  
DRWER TRACKS x 4  
CORREDERAS x 4

Utilize para medir as ferragens.

Utilice para medir el herraje.

Use for measuring the hardware.

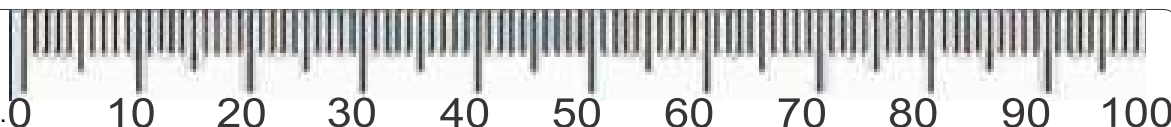

**Garantia (exclusivo para o Brasil/exclusivo de Brasil/exclusive to Brazil):**

A garantia dos produtos fabricados pela BRV Móveis, abrange eventuais defeitos-vícios de fabricação, no prazo estabelecido pelo código de Defesa do Consumidor, em seu artigo 26.II. o qual prevê a garantia de 90 (noventa) dias.

**A** = 19 KG - 41,88 LB

**B** = 7 KG- 15.43 LB

**C** = 2 KG- 4.40 LB

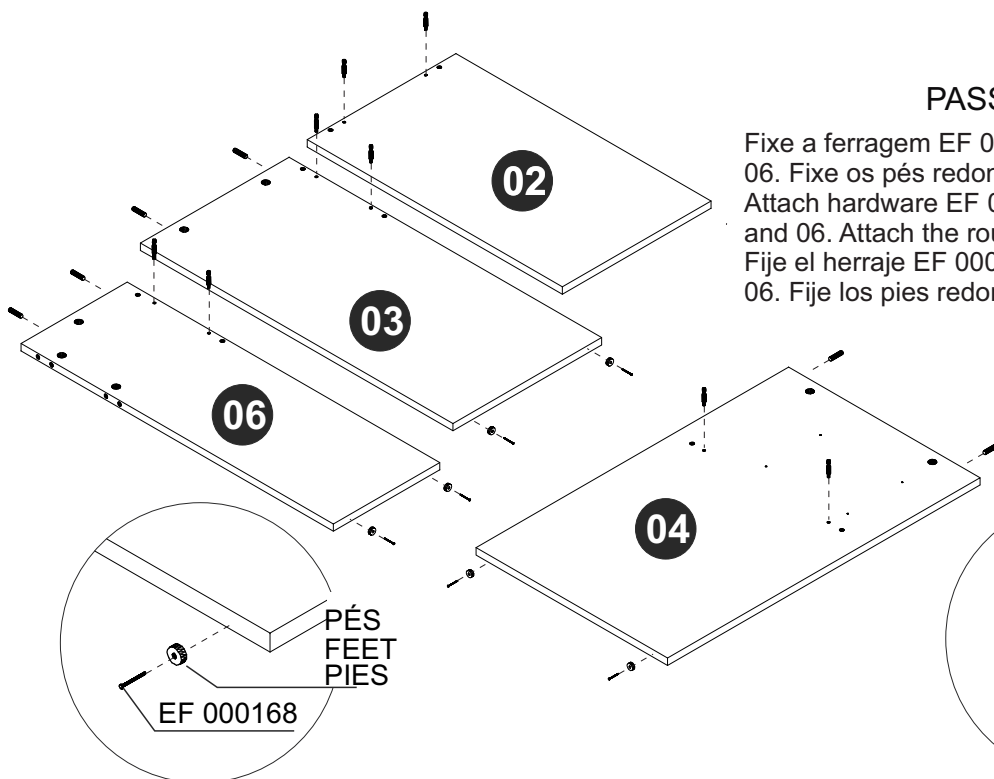
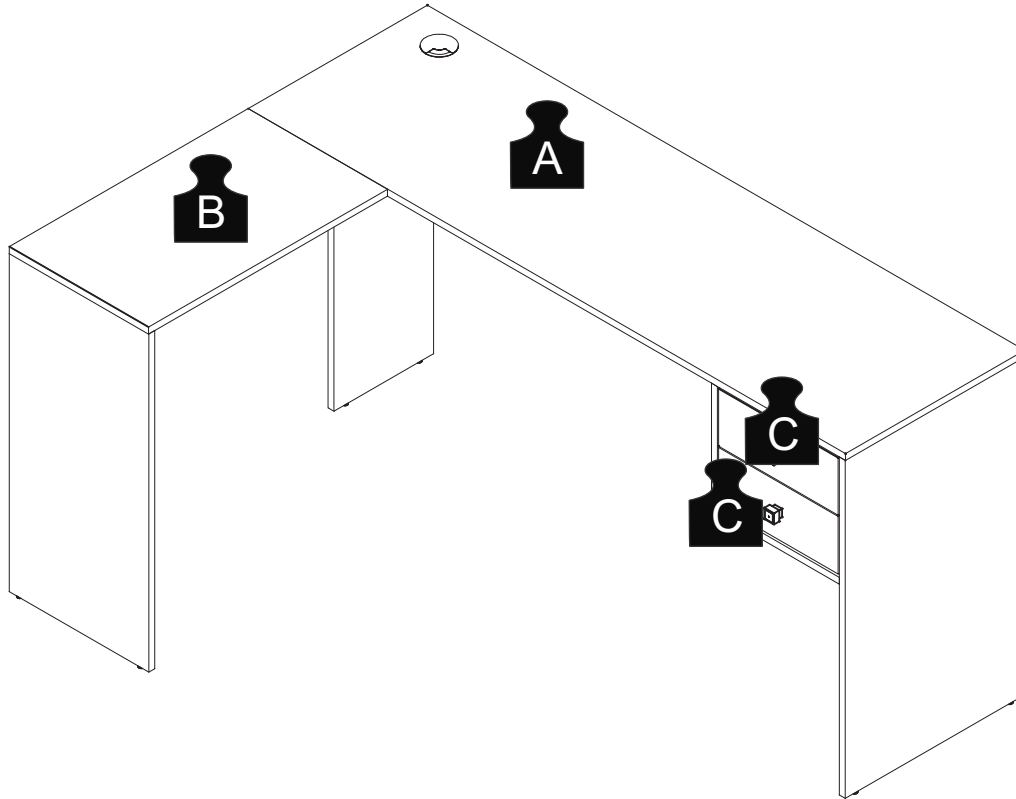

### PASSO 1 / STEP 1 / PASO 1

Fixe a ferragem EF 000094 e EF 000033 nas peças 02, 03, 04 e 06. Fixe os pés redondos usando a ferragem EF 000168.  
Attach hardware EF 000094 and EF 000033 in pieces 02, 03, 04 and 06. Attach the round feet using hardware EF 000168.  
Fije el herraje EF 000094 y EF 000033 en las piezas 02, 03, 04 y 06. Fije los pies redondos utilizando el herraje EF 000168.

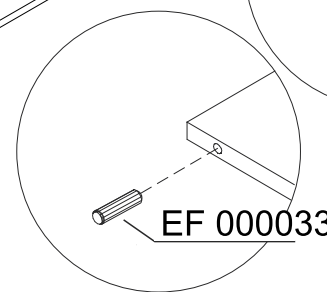
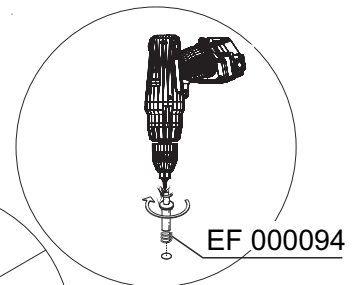



## PASSO 2 / STEP 2 / PASO 2

Insira a ferragem EF 000094 nas peças 01, 05, 10, 20 e 22.  
Insert hardware EF 000094 into pieces 01, 05, 10, 20 and 22.  
Añade el herraje EF 000094 en las piezas 01, 05, 10, 20 y 22.

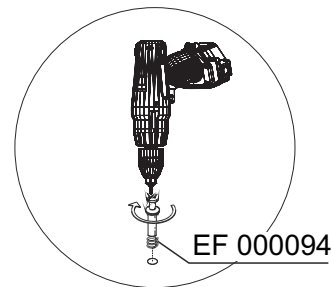
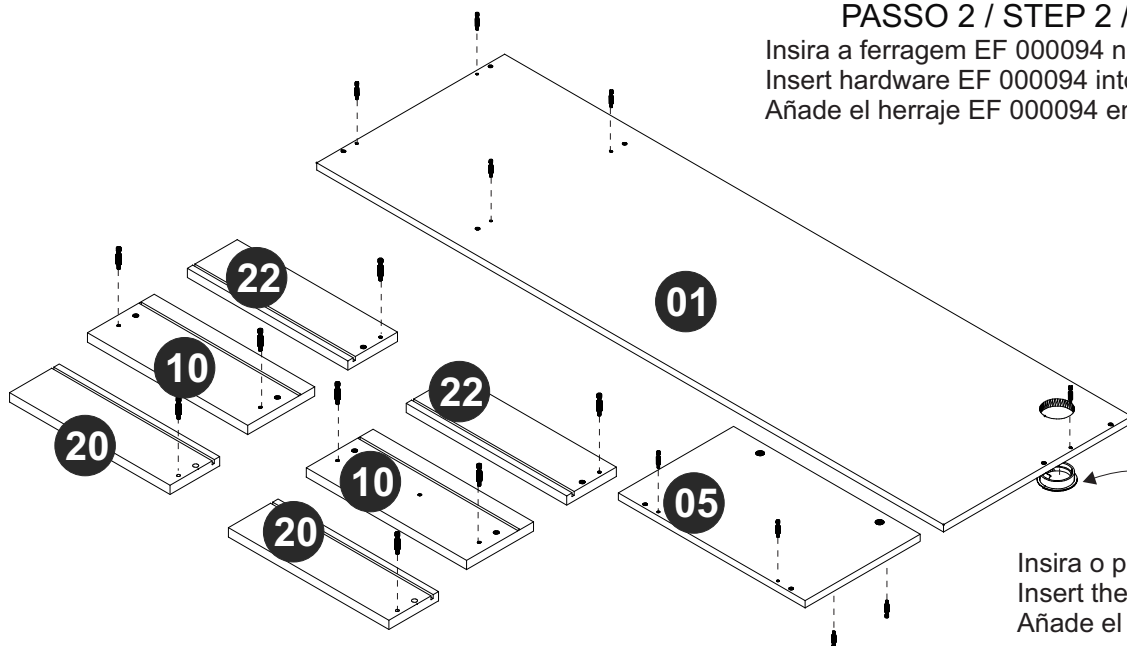

Insira o passa fio na peça 01.  
Insert the pass-wire into piece 01.  
Añade el pasa-cable en la pieza 01.

## PASSO 3 / STEP 3 / PASO 3

Insira a ferragem EF 000033 nas peças 05, 07, 08, 09, 20, 21 e 22.  
Insert hardware EF 000033 into pieces 05, 07, 08, 09, 20, 21 and 22.  
Añade el herraje EF 000033 into pieces 05, 07, 08, 09, 20, 21 y 22.

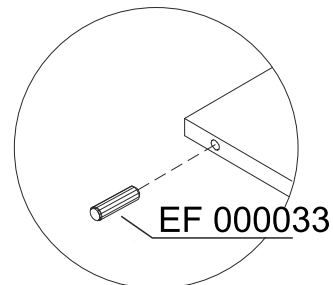
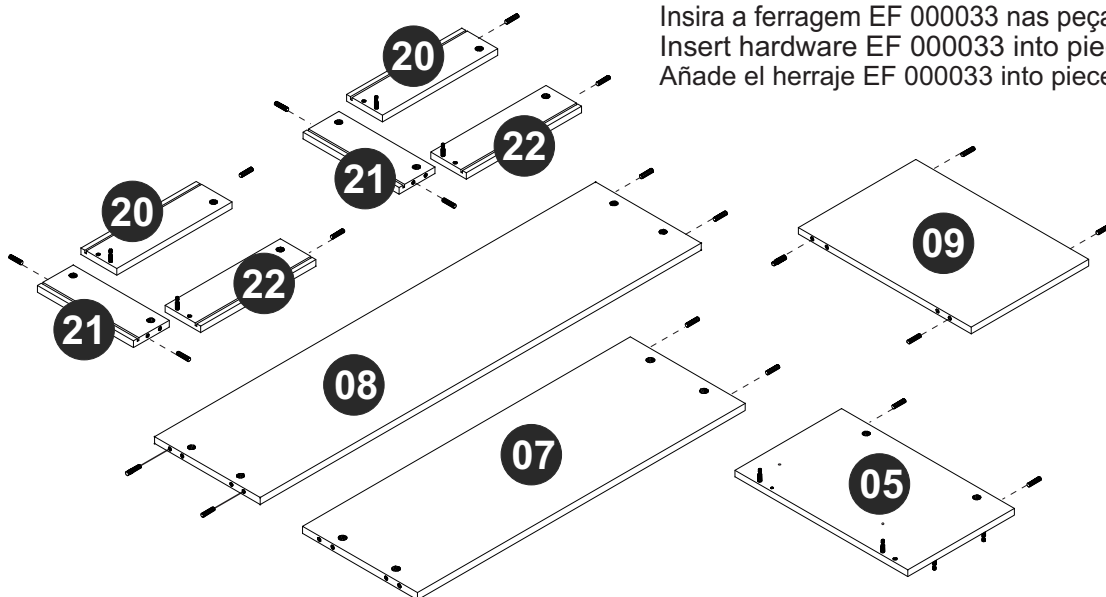

## PASSO 4 / STEP 4 / PASO 4

Fixe as corredeiras nas peças 04 e 05 utilizando a ferragem EF 000106.  
Attach the drawer tracks on pieces 04 and 05 using hardware EF 000106.  
Fije las correderas en las piezas 04 y 05 utilizando el herraje EF 000106.

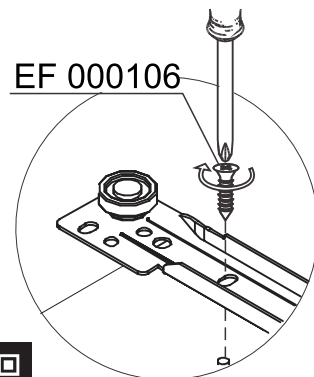
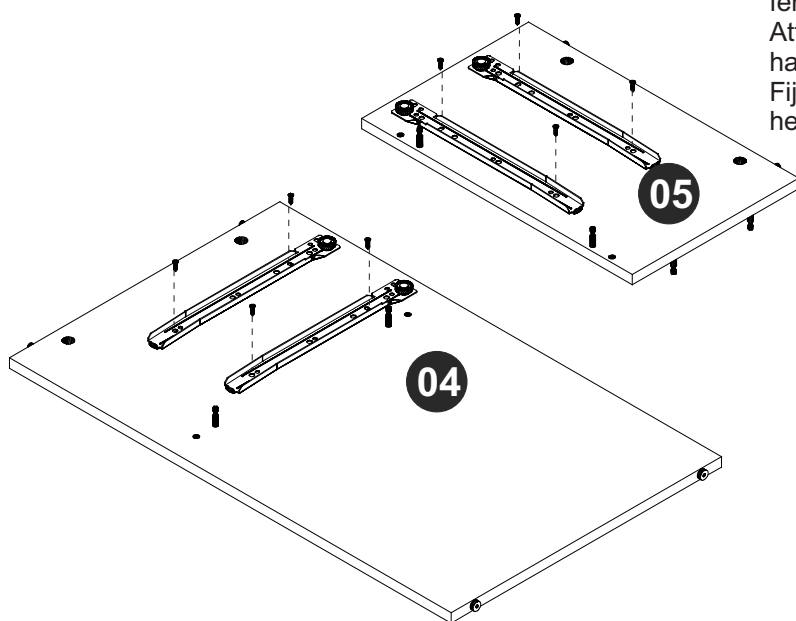

### PASSO 5 / STEP 5 / PASO 5

Conecte as peças 02, 03 e 07 insira a ferragem EF 000216 e gire para apertar.  
Connect pieces 02, 03 and 07, insert hardware EF 000216 and turn to tighten.  
Junte las piezas 02, 03 y 07, añáde el herraje EF 000216 y gire para apretar.

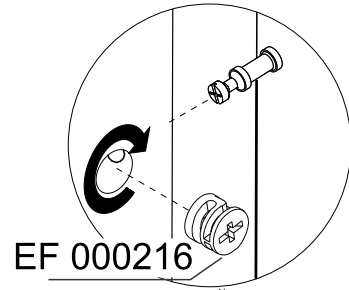
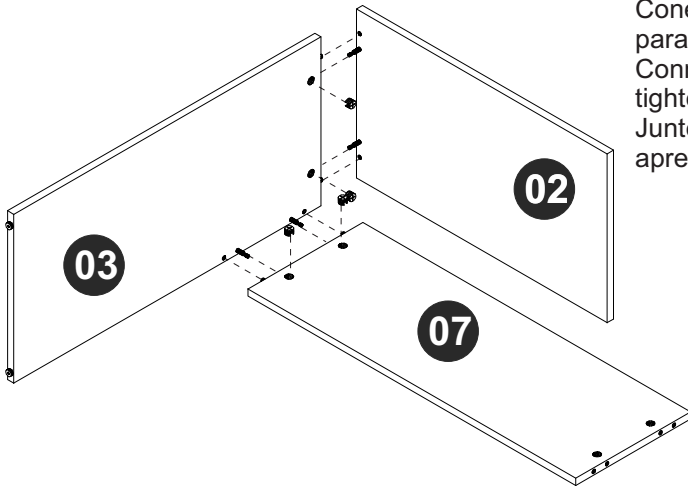

### PASSO 6 / STEP 6 / PASO 6

Conecte as peças 04, 05 e 09, insira a ferragem EF 000216 e gire para apertar.  
Connect pieces 04, 05 and 09, insert hardware EF 000216 and turn to tighten.  
Junte las piezas 04, 05 y 09, añáde el herraje EF 000216 y gire para apretar.

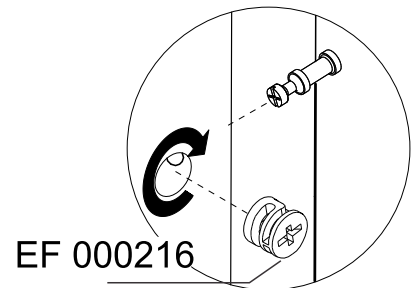
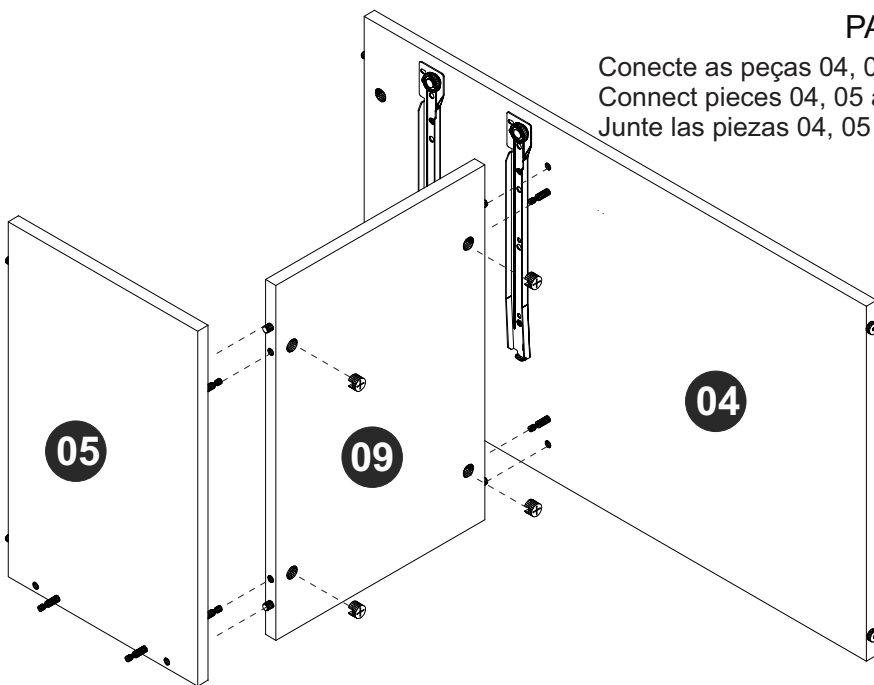

### PASSO 7 / STEP 7 / PASO 7

Conecte as peças 07 e 08, insira a ferragem EF 000216 e gire para apertar.  
Connect pieces 07 and 08, insert hardware EF 000216 and turn to tighten.  
Junte las piezas 07 y 08, añáde el herraje EF 000216 y gire para apretar.

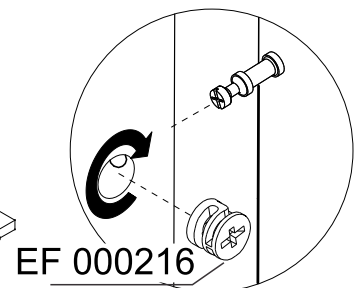
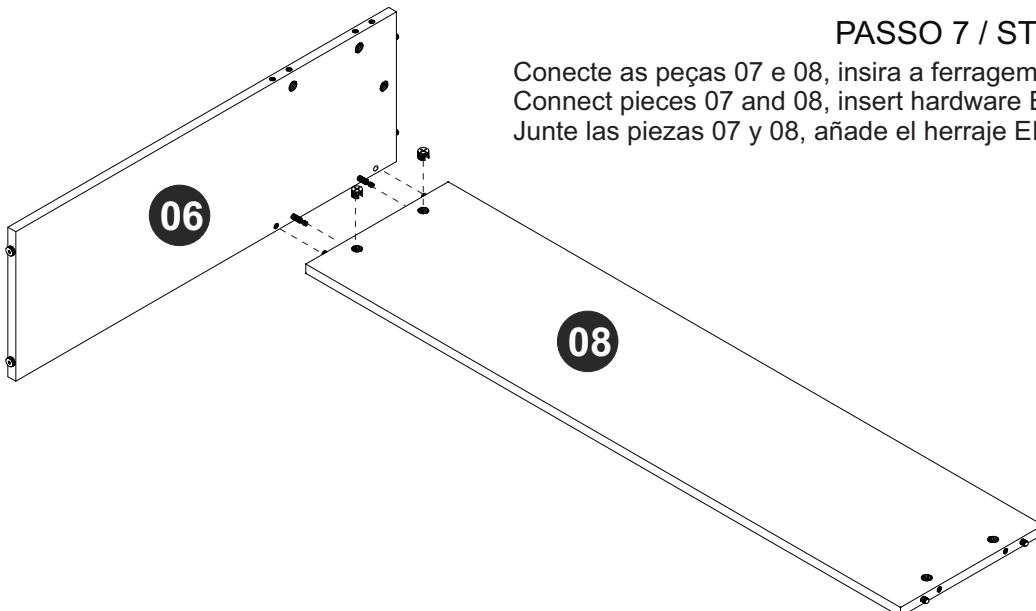

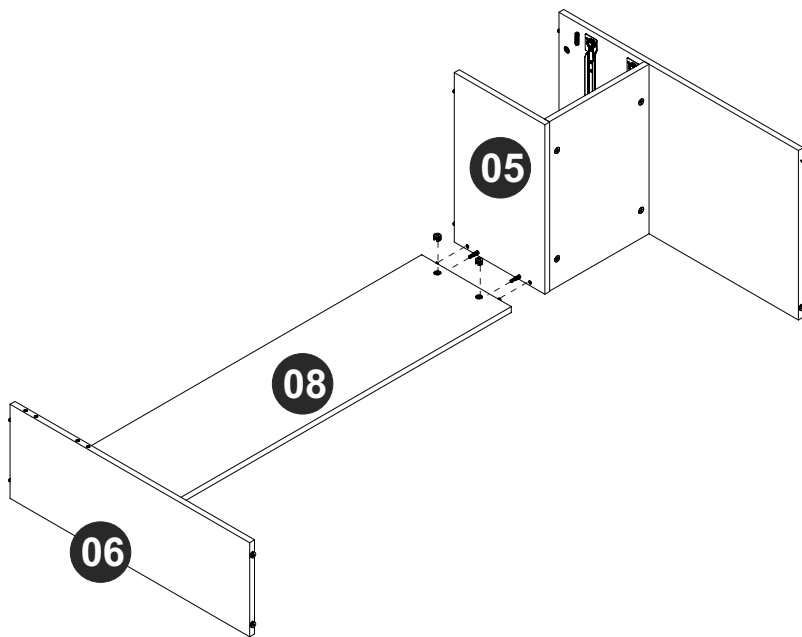

### PASSO 8 / STEP 8 / PASO 8

Conecte as partes montadas nos passos 6 e 7, insira a ferragem EF 000216 e gire para apertar.  
 Connect the parts assembled in the step 6 and 7 insert hardware EF 000216 and turn to tighten.  
 Junte las partes armadas en los pasos 6 y 7, añada el herraje EF 000216 y gire para apretar.

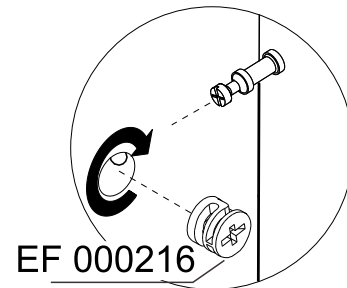

### PASSO 9 / STEP 9 / PASO 9

Conecte a peça 01, insira a ferragem EF 000216 e gire para apertar.  
 Connect piece 01, insert hardware EF 000216 and turn to tighten.  
 Junte las piezas 01, añada el herraje EF 000216 y gire para apretar.

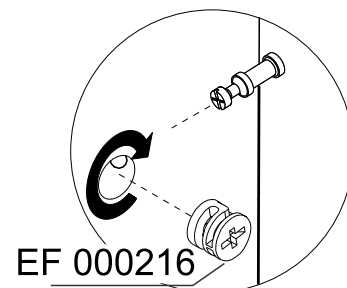
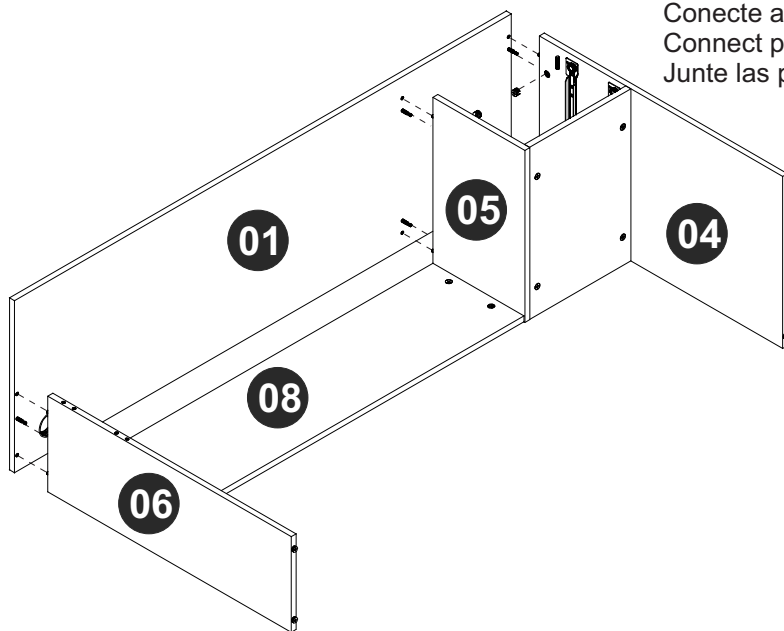

### PASSO 10 / STEP 10 / PASO 10

Insira as ferragens EF 000750 e EF 000724 para unir as peças 06 e 07. Insira a ferragem EF 000216 e gire para apertar.  
 Insert hardware EF 000750 and EF 000724 to join pieces 06 and 07. Insert hardware EF 000216 and turn to tighten.  
 Añade los herrajes EF 000750 y EF 000724 para juntar las piezas 06 y 07. Añade el herraje EF 000216 y gire para apretar.

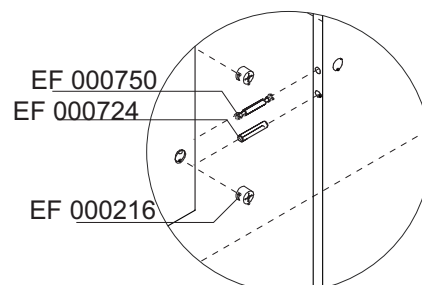
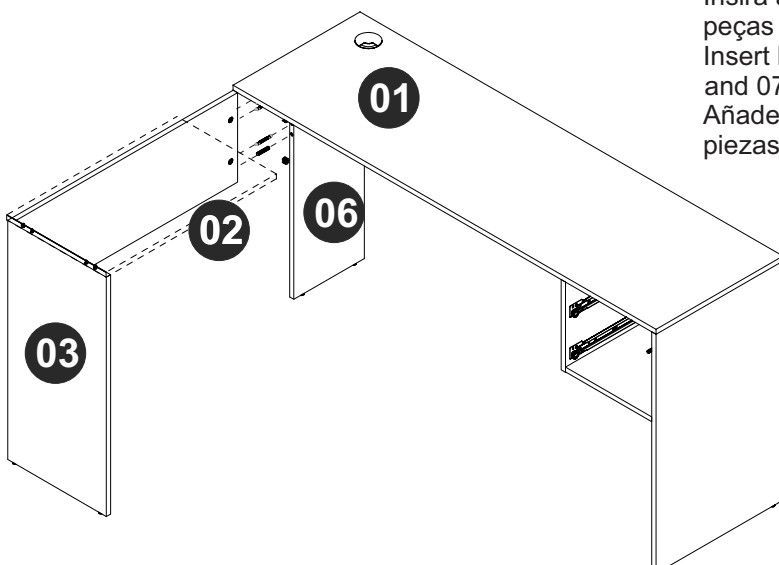

### PASSO 11 / STEP 11/ PASO 11

Conecte as peças 01 e 02 utilizando as ferragens EF 000069 e EF 000106.  
Connect pieces 01 and 02 using hardware EF 000069 and EF 000106.  
Junte las piezas 01 and 02 utilizando los herrajes EF 000069 y EF 000106.

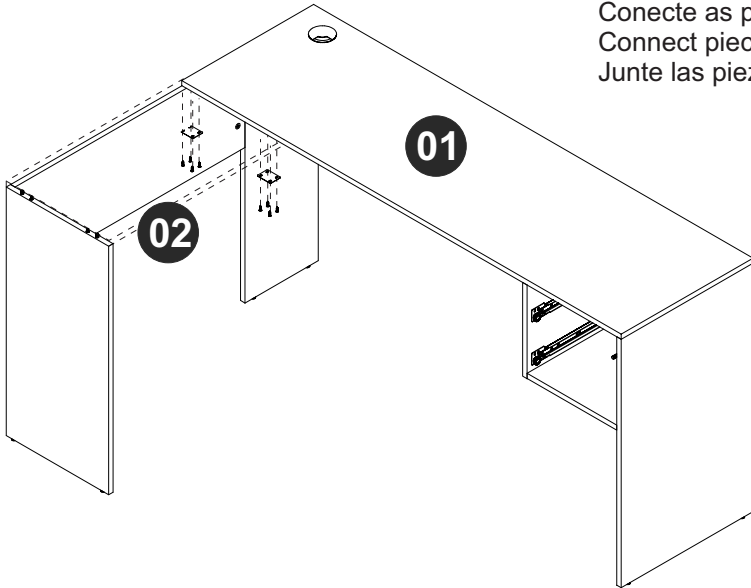

EF 000069

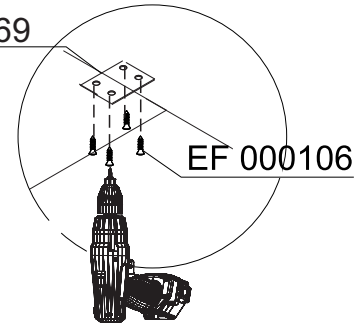

EF 000106

### PASSO 12 / STEP 12 / PASO 12

Fixe a peça 12 ao móvel utilizando a ferragem EF 000168.  
Fix piece 12 at the furniture using hardware EF 000168.  
Fije la pieza 12 al mueble utilizando el herraje EF 000168.

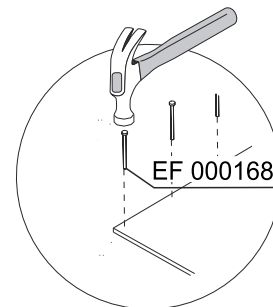
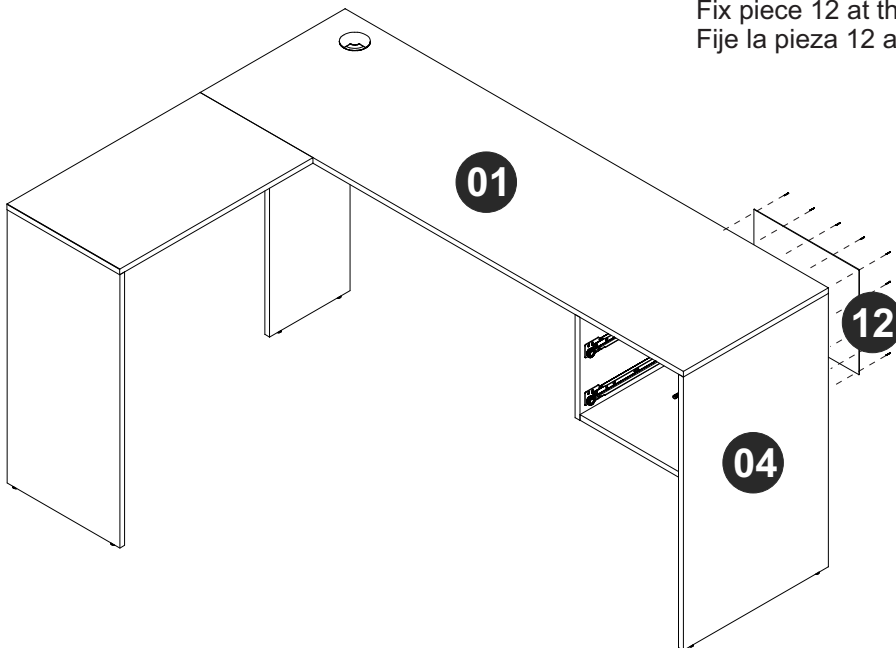

EF 000168

### PASSO 13 / STEP 13 / PASO 13

Conecte as peças 20, 21 e 22, encaixando as ferragens EF 000094 e EF 000216 e gire a ferragem EF 000216 até apertar.  
Connect pieces 20, 21 and 22 fitting hardwares EF 000216 and EF 000094, turn hardware EF 000216 to tighten.  
Junte las piezas 20, 21 y 22, encajando los herrajes EF 000094 y EF 000216 y gire el herraje EF000216 hasta apretar.

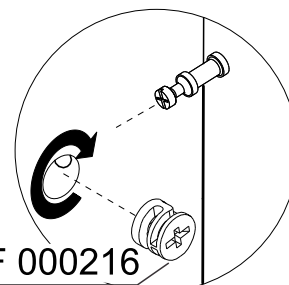
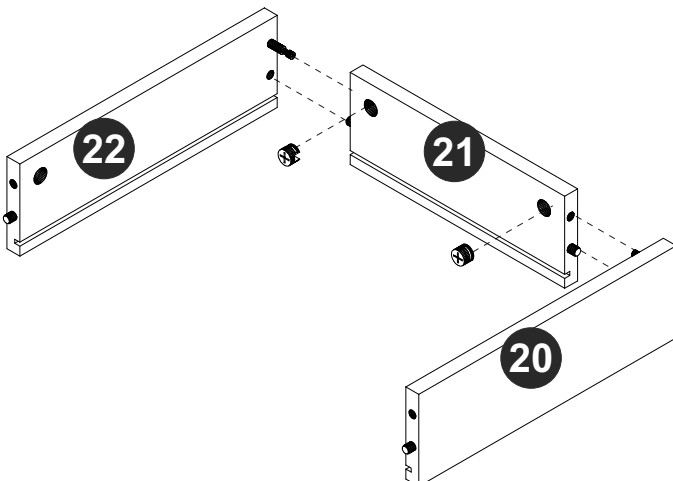

EF 000216

### PASSO 14 / STEP 14/ PASO 14

Encaixe a peça 12 entre os espaços específicos nas peças 20 e 22.  
Fit piece 12 through the specific spaces in pieces 20 and 22.  
Añade la pieza 12 entre los espacios específicos en las piezas 20 y 22.

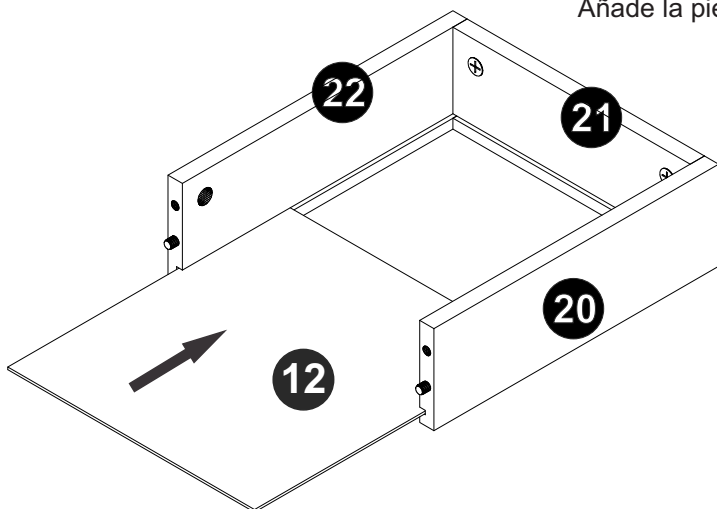

### PASSO 15 / STEP 15 / PASO 15

Encaixe a peça 10, insira a ferragem EF 000216 e gire para apertar.  
Fixe a peça 10, insert hardware EF 000216 and turn to tighten.  
Fije la pieza 10, añade el herraje EF 000216 y gire para apretar.

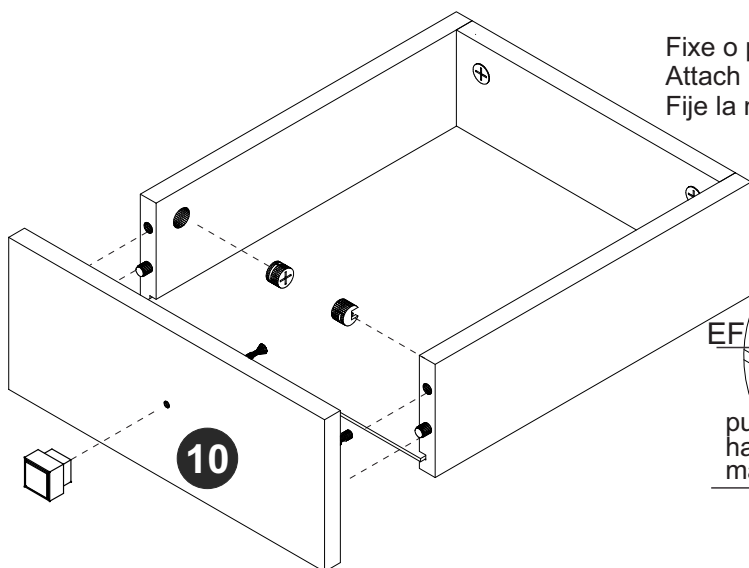

Fixe o puxador no local indicado usando o parafuso EF 000112.  
Attach handle at the indicated place using hardware EF 000112.  
Fije la manija en el local indicado utilizando el tornillo EF 000112.

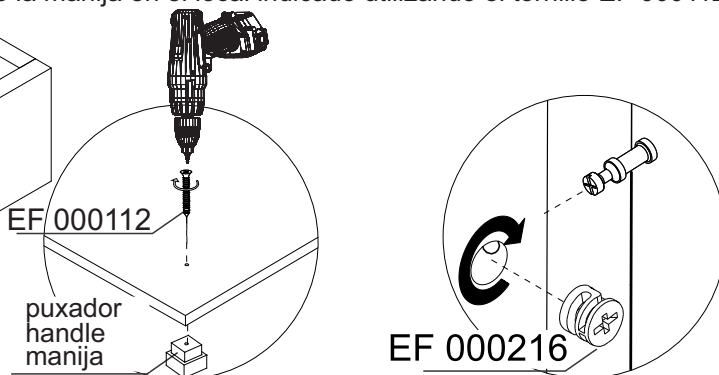

### PASSO 16 / STEP 16 / PASO 16

Fixe as corrediças de acordo com a imagem.  
Attach the drawer track according to the image.  
Fije las correderas de acuerdo con la imagen.

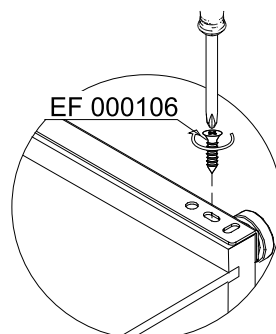
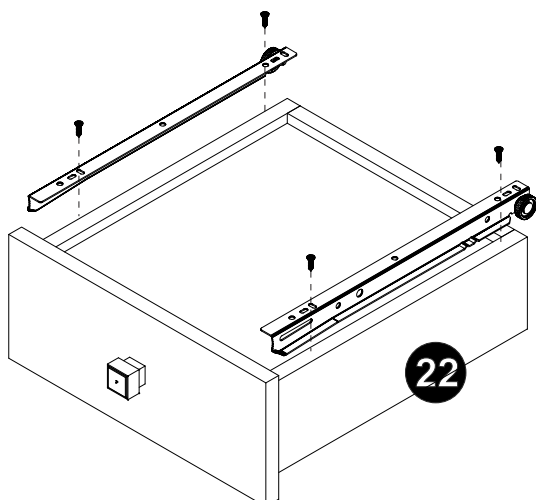

### PASSO 17 / STEP 17/ PASO 17

Utilize o tapa furos para cobrir os parafusos aparentes.  
Use the sticker to cover the apparent screws.  
Utilice los tapa huecos para cubrir los tornillos aparentes.

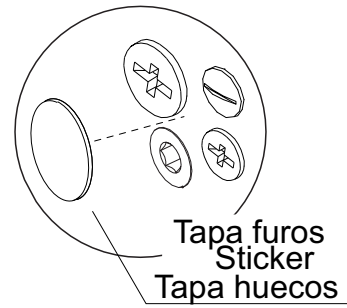
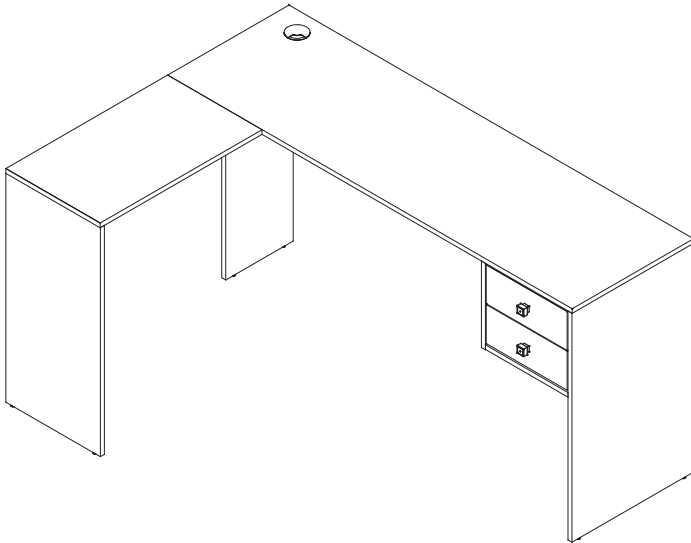

### PASSO 18 / STEP 18 / PASO 18

Utilize o giz para dar o acabamento final ao produto.  
Use the chalk to give the final finish on the product.  
Utilize la tiza para dar el acabado final al producto.

